



Nexans Cables Distributed by
Warm Your Floor
 23151 Alcalde Dr Ste B-1, Lag. Hills, CA 92653
 Toll Free Phone 1 - 866 - 558 - 3369
 Toll Free FAX 1 -866 - 558 -2010



Now you're getting warmer!

TXLP Snow & Ice Melting Cable Instructions

Installation Of The Heating Cable

IMPORTANT NOTE: THESE CABLES ARE NOT TO BE INSTALLED IN WALLS OR CEILING FOR ANY REASON AND MUST BE INSTALLED BY A QUALIFIED, LICENSED ELECTRICIAN.

NEVER:
 Cross the blue heating cable section over itself.
 Cut the blue heating cable section for any reason.
 Cross a true concrete expansion joint.
 Run the blue heating cable section directly into the junction box.
 Subject any part of the blue cable to harmful surfaces.

ALWAYS:
 Follow local and national electrical codes.
 Test the cable for the proper readings before, during and after the installation.
 Make certain the splice is completely buried in the pour
 Fill out the warranty card and return it to Orbit.

GENERAL INSTALLATION GUIDELINES

Description: Heating cables are delivered as factory custom made heating systems, which are a pre-determined length of single conductor heating cable with the two conductor ends spliced to non-heating leads. The heating cables are custom designed under precise specifications and can not be altered for any reason and are not interchangeable with other cables..

Loading: Heating cables covered by this installation instruction can be used with the following **MAXIMUM** values:

- Outdoor in Concrete: 55 watts/sq. ft. - 15.2 watts/linear ft.
- Outdoor in Asphalt: 32.5 watts/sq. ft. - 10.5 watts/linear ft.
- Outdoor in Pavers: (In Sand) 48 watts/sq.ft., 10.5 watts/linear ft. (In Concrete) 55 watts/sq. ft. - 15.2 watts/linear ft.
- Outdoor in Gutters: 7.5 watts linear ft.
- Outdoor on Roofs: 22 watts/sq. ft. - 7.5 watts/ linear ft.
- Voltage: 120, 208, 220, 230, 240, 277, 460 and 480.

The relationship between supply voltage, linear resistance, cable length and center spacing are important, as they need to be understood in order to give the right operating temperature and surface temperature distribution. The TXLP heating cable can be installed within the confines of Concrete, Asphalt, Mortar, Sand or any non-combustible material.

Electrical code and safety: All heating cable installations shall be installed according to the National Electric Code (NEC) Article 426 for outdoor deicing and snow melting and article 424 for space heating. **(In addition, the installation shall be in accordance with the regulations of all authorities having jurisdiction.)** **Caution:** This equipment shall only be installed by qualified personnel, who are familiar with the construction, operation, installation and hazards involved in outdoor environments. UL listed weatherproof materials shall be used along with Marker Plate(s) per all governing Local, UL and NEC requirements.

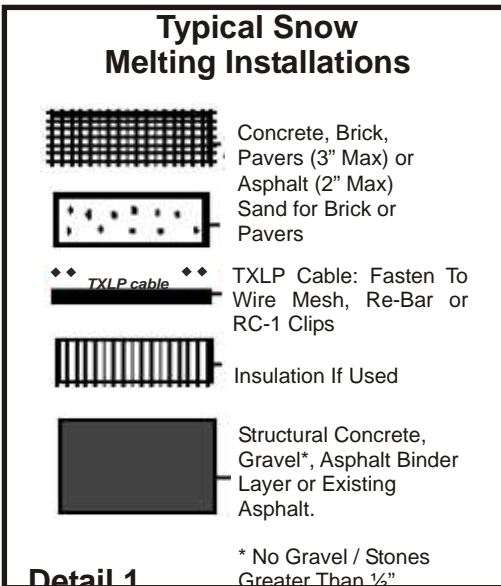

Cable & Splice Identification

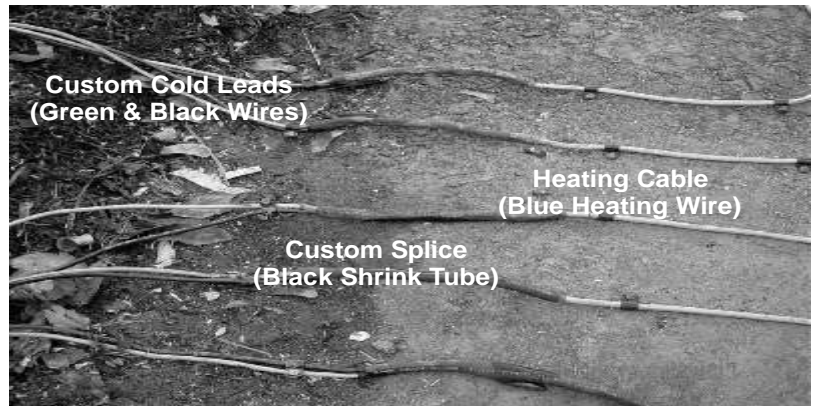

CONCRETE APPLICATIONS (Cable Depth, Min. 1" - Max. 3" From Surface)

FLAT AREAS: Install re-bar or wire mesh in the area to be heated.

Tie heating cable to re-bar or wire mesh with wire ties.

EXTERNAL STAIRS: The cable should be laid lengthwise on the steps so that they only lie on the horizontal surfaces. Detail 3 shows a section of a stairway with heating cables laid directly on the concrete. For installations of this kind it is essential to have a roughcast concrete step as a base. The cables should be installed with the first run no more than 2" from the front edge of the step. Then refer to UL Tag for number of runs per step and lay the remaining cable spaced evenly on the step tread.. **(DISREGARD THE SPACING FORMULA WHEN DEALING WITH STEPS)** When

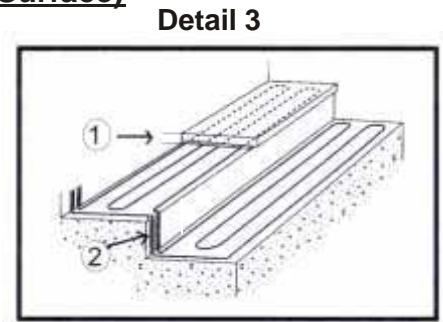

running the cable up the riser of the step it is suggested that a groove be made in the riser in order to keep the cable flat.

LAYING OF THE CONCRETE: Concrete can be poured directly from the cement truck and spread and leveled manually.

1. 2" Cover

2. Grooves made in the risers.

PAVERS IN SAND APPLICATIONS (Max. Cable Depth 4" From Paver Surface)

A minimum of 1" of compacted sand should be applied for the base to lay the cable on. DO NOT lay the cable down directly on the stone base or any other sharp surface. The cable should be arranged and tied down to wire mesh / deer fencing or equivalent, following the UL Tag "on center" spacing formula using cable ties. A minimum of 1" of compacted sand should then be applied on top of the cable. After the sand is compacted the final layer of Pavers can be installed.

ASPHALT APPLICATIONS (Cable Depth Should Be 1 1/2" - 2" From Surface)

DRIVEWAYS (With Complete Cable Coverage) Cable can be installed directly on the binder layer the existing driveway with our CMC-1 mounting clips and 2" round serrated masonry nails spaced no further than 18" apart or tied to wire mesh. (See Instructions Below For "Laying Of Asphalt").

TIRE TRACKS: The cable is laid across the tire tracks and secured with our CMC-1 mounting clips and 2" round serrated masonry nails or tied to wire mesh. (See "Mat" Section below) It can be laid on the binder layer or on the existing driveway. (Routing channels for heating cable installation is not an approved method and can cause pre-mature cable failure)

Laying Of The Asphalt: It is required that all asphalt be laid manually. Top coat grade material must be used and hand shoveled to cover the cable then using manual panel vibrators for compacting. A rubber tired paving machine can then be used when applying the final layer and a **small** roller for compaction but great care must be taken not to damage the cables. **(NO TRACK MACHINES, RUBBER OR METAL CAN BE USED)** Top coat thickness must be between 1 1/2 and 2 inches. The temperature of the asphalt cannot exceed 275 F. **Don't start or stop the roller on any type of grade where a cable is buried. Damage will result to the insulation and compromise the integrity of the cable.**

Mats: Our cable can be pre-assembled on many sub-straight such as chicken wire, safety netting and deer fencing to fabricate a mat system. Tie the cable with standard wire ties every 1 foot and make sure the cable is running across the shorter dimension and clip the ends of the cable ties. These mats are a time saver when dealing with large or long and narrow areas.

Marker Plate: Install the supplied Marker Plate(s) in a clear and visible location as per NEC requirement described below.

NATIONAL ELECTRIC CODE ARTICLE 426, SECTION 13 "The presence of outdoor electric deicing and snow melting equipment shall be evident by the posting of appropriate caution signs or markings where clearly visible"

Multiple Cable Layout

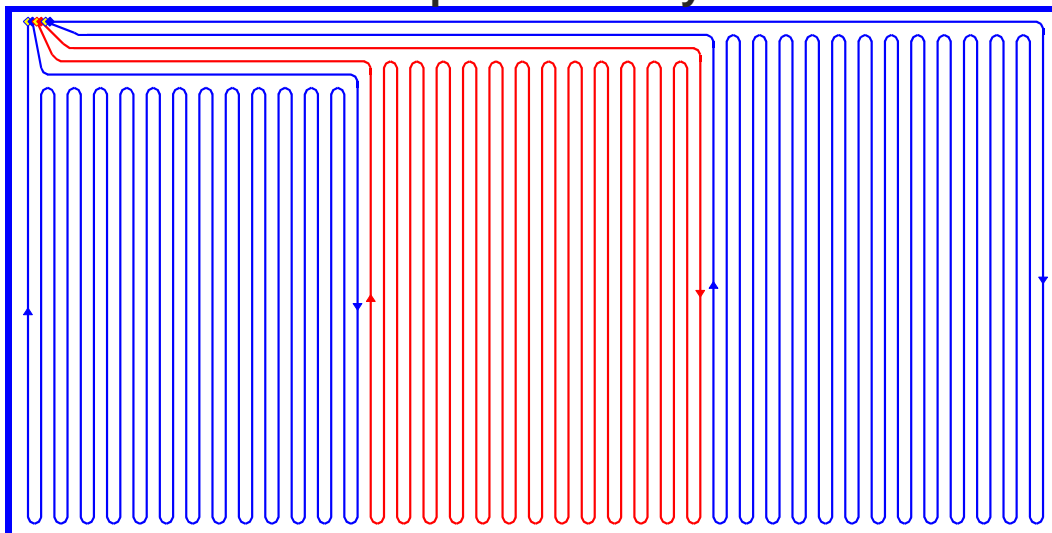

GENERAL INSTALLATION INFORMATION

Before You Start:

Field measure the area for which the cable is designed. Verify the area for the project is the same as the area originally designed. If the area has changed (larger or smaller), please call the factory to assure that the cable will be effective and operate in a safe manner. If you have any questions, it is important to contact our Tech Support Department. Any changes to the pre-determined design area can seriously affect the performance of the system.

General Rules:

The heating cables must be evenly distributed. Please use the factory designated spacing between the cables. This number is found on the UL Flag Tag that is attached to each cable. **It is very important for the cable spacing to be held to the design parameters in order to avoid installation problems.** The base for concrete should be compacted and stone and other sharp objects, which can damage the cables, should be cleared away before laying the cable. Depending on the application, the thickness of the final covering must not exceed the maximum (Page 1) allowed. This is to insure that there is adequate transfer of heat to the surface. Any variation of this thickness may cause poor performance or possible damage to the heating cables.

The direction of the cable layout is not important in asphalt or pavers in sand. In concrete it is strongly recommended to lay the cable across the shorter dimension of the space. (Below Right) If for any reason the concrete cracks, it normally cracks across the shorter dimension. It is important that the cable finishes at the same point it started, which is usually a junction box. (Lower Right) **(The lead wire can be run underground and into a building through an approved conduit per NEC. If the lead wire must be run in the heated area, it must be run in conduit).** Decide where you are going to start and end each of your cable(s) within the design area. Start by laying the cable with the splice, making sure the splice (heat shrink) is buried into the pour. We recommend attaching the cable every 12 - 18 inches to assure no movement while embedding within the pour. Run the cable along the outside edge of the design area, half the "on center" spacing (located on the UL flag tag) to the furthest point away from the starting point (See Diagram Below). After the interior edge is down, start to use the full "on center" spacing located on the UL flag tag and lay the cable in a serpentine fashion in order to fill the design area, ending the cable where it started. It is important to remember to maintain half the "on center" spacing dimension around the remaining outer edges of the design area. Where multiple cables are being installed (See Page 4) into one design, follow the layout until only enough cable remains unattached to make the homerun back to the starting point. Repeat as required.

INSTALLATION EXAMPLES

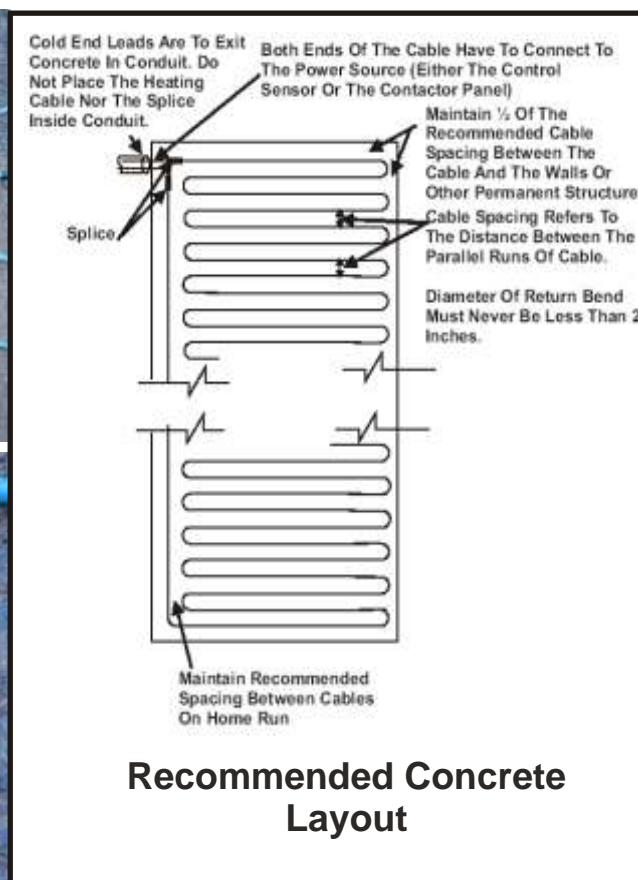

Recommended Concrete Layout

TESTING PROCEDURES FOR TXLP SNOW AND ICE MELTING CABLE

Cable Description: 2 Black (Non-Heated Power Leads), 2 Green (Ground Wires) Spliced To Each End of The Blue Heating Cable.

1. **Verify the cable you ordered is the one that you received. Refer to the UL flag tag that is attached to one of the black non-heated lead wires. This tag will list the following information: Watts, Volts, Cable Length, Cable Spacing, Ohms and Amps.**
2. **Visually check the cable for obvious flaws or breaks.**
3. **With a digital ohm meter, check your resistance between the two black wires. Reading should be between +/- 10% of the value listed on the UL tag. Record your readings for warranty registration purposes.**
4. **Again, using your digital ohm meter check the resistance between the black and the green wires, the reading should be 1999, all blanks or infinity.**
5. **Make sure all the blue heating cable and the splice are completely embedded in the underlayment. Only the black and green lead wires are permitted to be out of the pour.**
6. **During the installation of the topping, monitor the cable for any sudden changes in the ohms.**
7. **After the cable is installed, repeat steps 3 & 4.**
8. **When performing an actual amperage test, never run the cable for more than 15 seconds.**
9. **It's very important to take a photo of the cable layout prior to the pour to avoid any damage to the cable in the future.**

GENERAL INFORMATION

Thermal Insulation: Thermal insulation, if chosen or required, can be of a mineral wool or expanded polystyrene. The thickness depends on the local conditions, but normally 1-2 inches or R-12. When the heating cables are to be laid on top of insulation, cover the insulation with a wire mesh in order to prevent the cables from being pressed down into the insulation during installation.

Vapor Barrier: If a vapor barrier is required, it shall be of a non-metallic material such as plastic film. It must be located so that no damage can occur due to mechanical causes or by overheating from the cables.

Mechanical Integrity: When installing insulation and/or vapor barriers, it is important to make sure that the mechanical integrity of the pour is not compromised in any way.

Layout Restriction: Heating cables must be installed in open areas only. The layout requires that the entire heating cable be looped at even center spacing over the area that is to be heated. Both ends are terminated at a point where the power connection is made. Details of cable length, on center spacing, loading, etc. are given on UL Tag. **(Minimum distance between adjacent runs and minimum bending diameter is 2 inches).**

When installing, it is important to remember that all of the heating cables, including splices to cold leads, must be embedded so that only the non-heating leads are exposed outside the pour. By NEC standards a conduit is used to bring the leads out of the pour. Minimum distance between the heating portion of the cable and any combustible surface shall be 1/32 inch. The heating portion of the cable shall not touch, crossover, or overlap itself. As an option, measure and mark the center spacing within the design area as a reference for cable layout. Lay the heating cable out starting and ending in the same location. The cable must be laid at the calculated spacing. A template can be cut 1/4" less than the required center spacing. This will help insure the proper layout of the heating cable. Cables should be secured using approved means (See Page 4) as noted within these instructions. The cables should not be left unprotected for long periods of time or damage may occur. Concentration of heating cables around columns, drains, etc. may lead to overheating.

Outdoor Covering Materials: Asphalt, Concrete or Pavers (in sand or concrete) can be used as covering materials. covering and bonding materials must be able to withstand a continuous temperature of 122 degrees F (50 degrees C).

Temperature conditions: Heating cables should not be laid in temperatures below 25F as the outer plastic jacket becomes brittle at low temperatures and may crack as a result of an impact or jolt.