

Owner's Guide

Models 500650-120CS and 500650-240CS

The Watts Radiant 500650 programmable FloorStat will provide both energy savings and comfort.

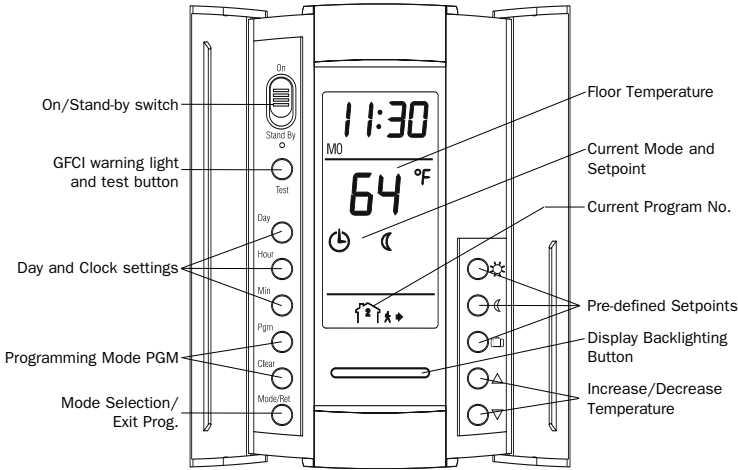

NOTE: The 500650 face plate must be mounted on a PB112 Series Power Base.

The FloorStat is designed to control the floor temperature. To avoid damage to your floor, we recommend you follow the supplier's instructions. The FloorStat is equipped with an On/Standby switch making it possible to put the FloorStat in "sleep" mode when its use is no longer required (i.e., summer). This will not affect the clock or programming.

1. SWITCH SELECTION

This FloorStat is factory-set to the following default values ():

Switch	Function	UP	DN
SW1	Temperature format*	°F	°C
SW2	Early start†	Disable	Enable
SW3	Time format	12 h	24 h

*If you switch from °F to °C or vice versa, the , , and setpoints may need to be redefined (only if setpoints were modified from their factory-set default).

† When using AUTO mode, the FloorStat calculates the optimum start time to obtain the desired temperature by the set time. The heating system could be started as early as 6 hours prior to set time when required. The FloorStat will automatically re-evaluate (every day) the optimum start time based on the previous day's performance.

Switches are located on the rear of the face plate. To modify, switch UP or DN.

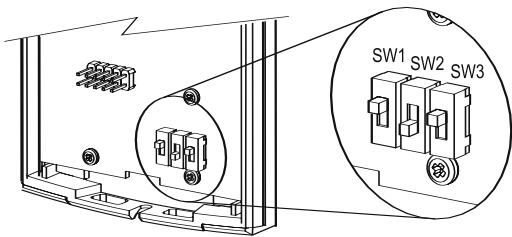

2. MOUNTING FACE PLATE

To mount the face plate onto the power base, refer to the diagrams below:

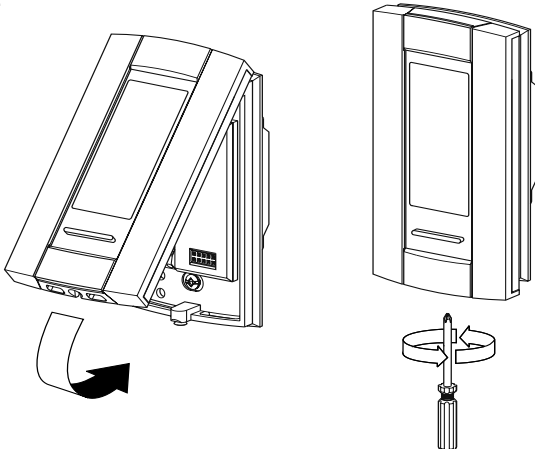

To remove the face plate from the power base, invert steps.

NOTE: The screw cannot be removed completely.

3. FIRST POWER-ON

When power is applied for the first time, the LCD displays: 0:00, MO (Monday), , and floor temperature.

1. Press **Hour – Min** to set the current time.
2. Press **Day** to set current day.

One of the two following messages may be displayed if the installation is incorrect:

- **LO:** The floor temperature is below 32°F (0°C), or the temperature sensor is defective, or not connected. The heating indicator (||||) is displayed and the relay is closed (energized).
- **HI:** The floor temperature is above 140°F (60°C), or the temperature sensor is defective.

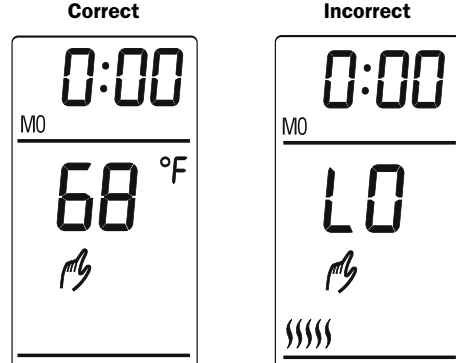

4. GFCI TEST

The GFCI monitors electricity flow for any loss of current; if there is, the thermostat will cut-off power to the heating system. We recommend you test the GFCI immediately after installing the control module, and once a month thereafter to ensure it is operating properly. To test:

1. Increase the temperature until the heating indicator (||||) is displayed.
2. Press **TEST**:
 - Successful: Test warning light is ON and power to heating system is cut-off.
 - Unsuccessful: the Test warning light is OFF. Cut power to heating system from the main power panel and call customer service.

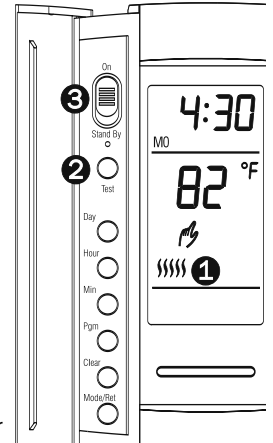

3. When successful, reset FloorStat (On/Standby) to power the heating system.

NOTE: If the warning light comes on during normal operation, cut power to heating system from the main power panel and have an electrician verify the installation.

5. TEMPERATURE SETPOINT

The 500650 thermostat is programmed with the following default temperature control setpoints:

Symbol	Setting	Default	New
	Comfort (when you are at home)	82°F (28°C)	°
	Economy (when asleep or away from home)	68°F (20°C)	°
	Vacation (away for prolonged absence)	50°F (10°C)	°

If you wish to modify a setpoint, follow these steps:

1. **Set** the desired temperature using the buttons.
2. **Press and Hold** the or or button.
3. Release button when symbol is displayed.
4. Press **Mode/Ret** to exit.

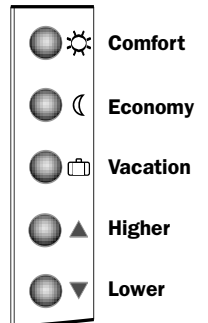

6. OPERATING MODES

This thermostat has three operating modes:

Automatic — Executes the Comfort/Economy programs as defined in the schedule.

1. To activate, press **Mode/Ret** until is displayed. A program icon (e.g.,) and corresponding setpoint (e.g., or) are also displayed.

Temporary Bypass — Maintains a specific temperature until the beginning of the next program. Set the desired temperature using the OR press or to use a pre-defined setpoint.

Manual — Maintains a manually-defined setpoint.

1. To activate, press **Mode/Ret** until is displayed.
2. Set temperature using OR press or to use Comfort or Economy setpoint.

Vacation — Maintains the Vacation setpoint when away for a prolonged absence (e.g., a vacation). Can also be done remotely through your telephone.

1. Press to activate.

7. DEFAULT SCHEDULE

AUTO MODE ONLY

The 500650 FloorStat is preprogrammed with the following schedule:

Prog	Setpoint*	MO	TU	WE	TH	FR	SA	SU
	82°F	6:00a	6:00a	6:00a	6:00a	6:00a	6:00a	6:00a
	68°F	8:00a	8:00a	8:00a	8:00a	8:00a	10:00a	10:00a
	82°F	5:00p	5:00p	5:00p	5:00p	5:00p	5:00p	5:00p
	68°F	10:00p	10:00p	10:00p	10:00p	10:00p	11:00p	11:00p

*To modify the Comfort and Economy setpoints, see Temperature Setpoint.

This schedule is defined with the following Economy and Comfort periods:

- Comfort: 6:00a to 8:00a and 5:00p to 10:00p.
- Economy: 8:00a to 5:00p and 10:00p to 6:00a.

The SunTouch 500650 controls the heating system according to the setpoints defined in the four programs.

NOTE: To reset the 500650, press and hold , position switch to Standby then to On. This will completely erase the schedule and any modified setpoints.

8. MODIFY THE SCHEDULE

- After 60 seconds of inactivity, the FloorStat will automatically exit programming mode.
- It is faster to program the same schedule for the entire week; then modify the exception days.
- See Temperature Setpoint for more information on how to modify the Comfort and Economy setpoints.
- You can program up to 4 different settings for each day of the week.

Prior to making changes, use this blank template to record your personalized schedule:

Prog	Setpoint	MO	TU	WE	TH	FR	SA	SU
	___°							
	___°							
	___°							
	___°							

Temperature format: °F °C

Time format: 12h 24h

Notes: _____

To modify, follow these steps:

1. Press **PGM** to access the programming mode
2. Press **Day** to select the day to be programmed (hold for 3 seconds to select all days of the week).
3. Press **PGM** to select the **Program No.** (1, 2, 3, or 4).
4. Press **Hour** and **Min** to set the time OR press **Clear** to clear the time (:- is disregarded).
5. Repeat steps 2 to 4 for remaining programs.
6. When completed, press **Mode/Ret** to exit programming mode.

Schedule Example:

This schedule is an example of the various possibilities:

Prog	Setpoint	MO	TU	WE	TH	FR	SA	SU
	82°F	5:00a	5:00a	5:00a	5:00a	5:00a	9:00a	9:00a
	68°F	8:00a	8:00a	8:00a	8:00a	8:00a	12:00p	12:00p
	82°F	4:00p	4:00p	4:00p	4:00p	4:00p	8:00p	8:00p
	68°F	9:00p	9:00p	9:00p	9:00p	9:00p	11:00p	11:00p

REMOTE INPUT

The FloorStat is equipped with a remote input which allows connection of a telephone controller or any other remote control system. When a signal is received through this input, the FloorStat will automatically switch from normal operating mode to Vacation mode (), or vice versa. You can, for example, heat your country house from your office on Friday, or your house from the airport, or from your car on your way back from vacation.

CHARACTERISTICS

This FloorStat works differently than a conventional electromechanical type. The latter can have a differential of temperature up to 7.2°F (4°C) while this electronic FloorStat has one of only 0.9°F (0.5°C). This slight oscillation eliminates the discomfort often found with conventional electromechanical thermostats. The proportional controller determines the amount of power required by the floor heating system to maintain the desired temperature setting.

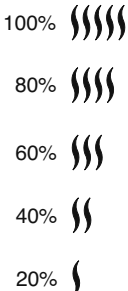

To see this process, the display shows, in real time, the percentage of power applied to the electric heating system.

Percentage (100% = 1 cycle)					
CYCLES	20%	40%	60%	80%	100%
15 min.	3 min.	6 min.	9 min.	12 min.	15 min.

Example for FloorStat with 15-minute cycles:

For example, when the screen displays  (which equals 40% or 6 minutes), then the heating system will be ON for 6 minutes, then OFF for the remaining 9 minutes of the 15-minute cycle. The heating indicators refresh when a new cycle starts.

TECHNICAL SPECIFICATIONS

Model: 500650-120CS (120 VAC) or 500650-240CS (240 VAC)

Display range: 32°F to 140°F (0°C to 60°C)

Setting range (ambient): 40°F to 86°F (5°C to 30°C)

Setting range (floor temp.): 40°F to 104°F (5°C to 40°C)

Comfort default: 82°F (28°C)

Economy default: 68°F (20°C)

Vacation default: 50°F (10°C)

Floor default temperature limit: 82°F (28°C)

Temperature variation: ±0.9°F (0.5°C)

Storage: -4°F to 120°F (-20°C to 50°C)

Temperature control: Proportional integral adaptive (analyzes the system's past cycles to optimize future commands), 15-minute heating cycles.

MEMORY BACKUP

In the event of a power failure, an internal circuit will maintain the programming. Only the time will have to be set if the power failure is more than two (2) hours. The FloorStat will return to the same operating mode as set before the power failure.

WARRANTY

WATTS RADIANT, INC. ONE (1) YEAR LIMITED WARRANTY

This product is warranted against material defects and workmanship in normal use for a period of one year, from the date of the original purchase from authorized dealers. During this period, Watts Radiant, Inc. will repair or replace the product with a new or of equivalent quality at Watts Radiant option, without charge, any product proven defective in normal use.

Warranty does not cover transportation costs. Nor does it cover a product subjected to misuse or accidental damage. This warranty does not cover the cost of installation, removal or reinstallation.

This limited warranty is in lieu of all other warranties, obligations or liabilities expressed or implied by the company. In no event shall Watts Radiant, Inc. be liable for consequential or incidental damages resulting from installation of this product. Some states or provinces do not allow limitations on how long an implied warranty lasts, or the exclusion or limitation of incidental or consequential damages, so the above exclusions or limitations may not apply to you. This warranty gives you specific legal rights and you may also have other rights which vary from state to state.

The defective product and the original sale receipt must be returned to the original dealer or shipped pre-paid, insured and addressed to:

Watts Radiant, Inc.
4500 E. Progress Place
Springfield, MO 65803-8816

If you have any questions concerning the installation or programming of this product, please call our technical assistance at **800-276-2419**.

Or...

Warm Your Floor

23151 Alcalde Dr. Suite B-1
Laguna Hills, CA 92653

Toll-Free 866-558-3369
Fax 949-855-2010

www.WarmYourFloor.com